



SMT-710

Wi-Fi Thermostat with Zone Control



User & Installer Manual

Ver 1.9





Welcome and Thank You for Choosing the Smart Temp SMT-710 Thermostat

Thank you for choosing the Smart Temp SMT-710 thermostat. Engineered for precision and reliability, this advanced device is designed to provide you with years of seamless climate control.

To get started and make the most of your new thermostat, please take a moment to read this manual. It will guide you through the setup process and help you maximize the benefits that your thermostat can provide.

For more detailed information, visit: www.smarttemp.com.au or scan the QR code below.

We're here to assist you—please share your feedback or reach out for support by emailing us at support@smarttemp.com.au







Smart Temp Australia P/L
www.smarttemp.com.au
support@smarttemp.com.au

Home Screen

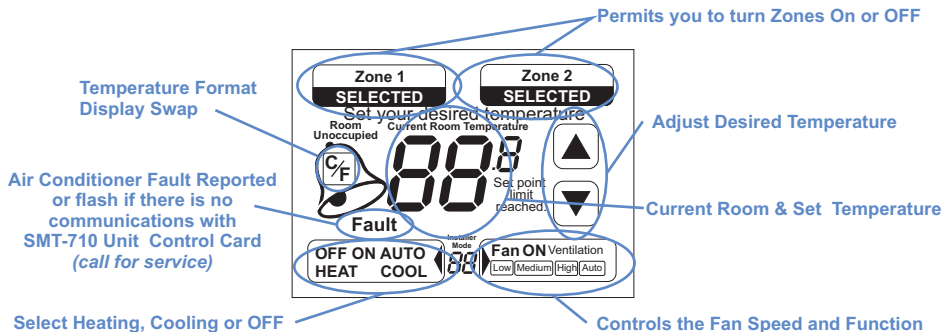
The SMT-710 is a compact yet powerful touchscreen thermostat designed for use in homes, apartments, and hospitality settings. It combines intuitive operation with a clean, modern interface, making it ideal for users who value simplicity and reliability.

All functions are accessed through a responsive touch interface that provides clear visual feedback, ensuring easy control of temperature and settings. The illustration below shows the full SMT-710 display layout and provides a basic overview of the key features and indicators. Detailed instructions and function descriptions can be found in the relevant sections throughout this manual.



Note - not all functions shown may be available on your SMT-710

Turning your SMT-710 On or Off & Changing Modes

The bottom left of the touch display shows the current mode that the thermostat using. Touching this area will permit you to toggle between all available modes as defined below.

Off- There will be no Heating or Cooling regardless of how warm or cool the room temperature becomes.*

Heat- The SMT-710 will control the heating system on to prevent the space from becoming too cool- it will maintain your Heat set temperature. The SMT-710 will not control the cooling system to prevent the space from becoming too warm.

Cool- The SMT-710 will control the cooling system to prevent the space from becoming too warm- it will maintain your Cool set temperature. The SMT-710 will not control the heating system to prevent the space from becoming too cool.

Auto- The SMT-710 will control the heating and cooling system on to maintain the desired temperature to within 1 deg C of the set temperature.

On- If the Text "ON" is shown in the SMT-710 display, your system has been set up to be "ON" or "OFF" only operation. When ON is displayed it will be in Auto mode and when OFF is shown, it will be OFF as described above. You will not be permitted to select Heat only or Cool Only mode.

* Note - there maybe safety set points enabled by the installer that will maintain a room temperature even when OFF mode is selected.
"E" will be shown flashing in the Display when these set points are in use. (shown in red)

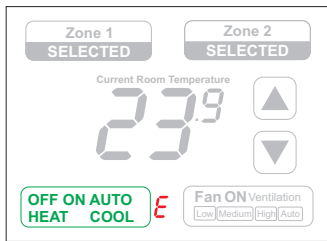

Adjusting your Set Temperature

Your SMT-710 saves the desired temperatures for each of its operational modes. These modes include Heat Only, Cool Only, and Auto.

As you swap between these available modes your previous set temperature for each of those modes will be used. Should you wish to adjust the set temperature use the Up/Down buttons to enter a new desired temperature. These values will now be saved for each mode.

Note, in Auto Mode (if Enabled) the cooling set temperature MUST be above your heating set temperature. (Note, your Installer may have set temperature control limits.)

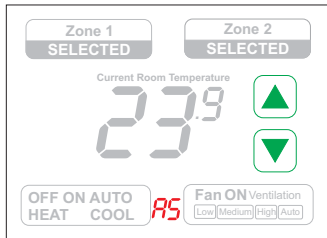

SMT-710 App Control- Scheduling

The SMT-710 has a Smart App that permits you to change mode and set temperature remotely. The App also permits you to pre-program automatic temperature changes so that the heat and cool set temperature will change automatically to follow your daily living schedule.

If your SMT-710 is using the App Schedule the text "AS" (shown in red) will be displayed. If you use the Up/Down button to override the App Scheduled temperature the text "AS" will not be seen. The overridden temperature will remain in effect until the next scheduled change is made by the App where AS will return.

Zone Control

The SMT-710 can be optionally set up and wired to control the flow of conditioned air into two areas, we call these areas “Zones”. Typically these zones are used as Living / Bedroom or Upstairs / Downstairs Zones.

Using the Zone Function within the SMT-710 you are able to allow or restrict the flow of conditioned air into each of these zones. This can be useful to reduce energy consumption (by only sending conditioned air to the Zones you are currently occupying) or to improve comfort by independently measuring and controlling each zone’s temperature (Zone 2 sensor required). Zone 1 is the zone in which the SMT-710 wall controller is located.

Two buttons at the top of the SMT-710 display are used to control these zones. The text “Selected” indicates that “this zone” will receive conditioned air. Tap the button to toggle between selected and not selected.

Note - Depending on the preferences of the air conditioning system, you may not be able to close both zones simultaneously. Additionally, your choice of fan speeds may be limited if only 1 zone is open.

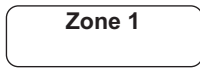

(Zone Closed)



(Zone Open)

Temperature Measurement

If zone 1 is selected the display will show the Zone 1 temperature (or if both Zone 1 & Zone2 is selected). If an optional Zone 2 sensor is fitted and only Zone 2 is selected, the display will show the Zone 2 temperature . *(Any time you wish to see the Zone 2 temperature press and hold the Zone 2 button for 2 seconds).*

If your SMT-710 does NOT have a zone 2 sensor fitted, it will assume that both Zone 1 and Zone 2 temperature are the same and control accordingly.

Using the App

The SMT-710 is fitted with a Bluetooth and Wi-fi Radio. These devices permit you to easily pair your SMT-710 to your home or office Wi-Fi network so that you can remotely control most functions of the thermostat from anywhere in the world where you have access to the internet.



The SMT-710 uses the TUYA network, permitting you to group the SMT-710 onto the same App that many of your other TUYA devices may use. We recommend the Smart Life app for the SMT-710.

Pairing

If you have your TUYA app (Smart Life for example) running when you first power your SMT-710, the App will pop up with an alert indicating that it has found a new device and request that you pair. Agree and follow the App prompts.

Re-Pairing

If you wish to re-pair the SMT-710 to a new network at a later date (or if the Auto Pairing above does not work) you can force the SMT-710 into pairing mode.

With the Mode set to Off, press and hold the right hand side of the LCD for 5 Seconds. Turn pairing mode on with the Up Button then start the process by pressing the bottom left button. Pairing mode will last for 30 seconds. The app (if running) should detect the SMT-710 is in pairing mode and the process should start as described above.

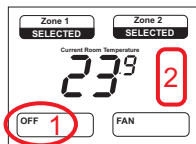

Ensure SMT-710 is OFF.
Press and hold the
area shown for 5 seconds

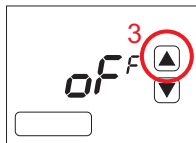

Use the Up button to
show "P"



Press lower left button
to start the pairing process

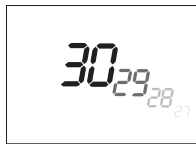

SMT-710 will count down and auto
exit pairing mode in 30 seconds

Important Notice: Installer Menu Access

The SMT-710 Thermostat includes a PIN-protected Installer Menu, ensuring secure access to critical system settings.

This menu allows for adjustments that directly affect the thermostat's control over the connected heating and cooling system.

 Caution: Modifying these settings can significantly impact system performance and functionality. Do not access this menu or make changes unless you fully understand their consequences.

Incorrect adjustments may damage the system and may void both the SMT-710 thermostat and HVAC system warranties.

For assistance, consult a qualified HVAC professional.

Wiring Overview

The SMT-710 is comprised of two separate parts, being the touch screen wall controller and the Unit Control Card (UCC). The wall controller is the user and installer interface and the UCC has the inputs and outputs to control the HVAC system, the zone dampers and also any sensors or fault inputs etc.

There are 4 wires that join these two parts. 2 wires used for power and 2 wires are used for data communication. The wall controller and UCC terminals are each labelled 1, 2, 3 & 4.

24VAC is applied to terminals 1&2 (Such as provided by the optional SZ-PS power supply). Terminals 3 and 4 share data between the Wall Controller and UCC.

Relays for equipment on the UCC are rated at 240V @ 10 amps.

The TT and the Assignable input terminals are strictly VOLT FREE
DO NOT apply power to these inputs as damage will result.

The 0-10V outputs for Heat Cool and Fan can source a maximum

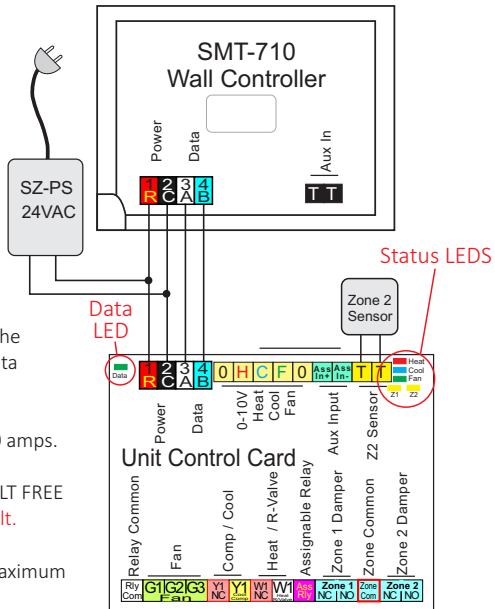

Terminal Overview

Wall Controller

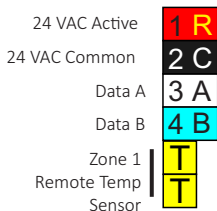

Note

Assignable input is Volt Free
DO NOT apply external voltage to this input
(Ass In- is connected to 0v Com terminals)

Unit Control Card

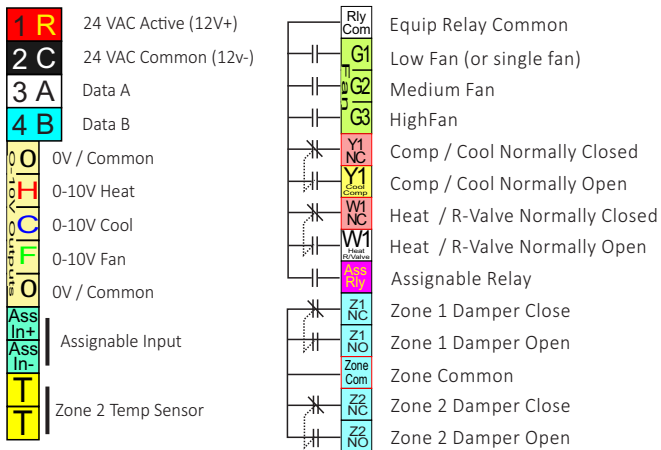

If powering the SMT-710 with 12VDC, ensure Positive to 1(R) and Negative to 2 ©

DIP Switches

Hardware Switches preserve the core control functions that must be able to survive a factory reset (or should be able to be configured before power is available).

Equipment control modes, fan logic and zone control can be set with these switches. The table to the right explains these switch functions.

Switch	Function	Off	On
1	Fan Speeds	1 Speed	3 Speed
2	Equipment Type	Heat Cool	Heat Pump
3	If Dip 2 ON (HP)	R/Valve Cool	R/Valve Heat
	If DIP 2 Off (H/C)	Heater Calls Fan	Thermostat Calls Fan
4	Not Used		
5	Comp Delay	Off	On - 5 Min
6	Not Used		
7	Ventilation Mode	Off	On
8	Zone Enable	Off	On

Note. Switch 3 function is based on the position of switch 2.

(Sw 1, 2,3 &5 on by Default)

Dip 2 OFF (Heat add on Cool Mode) DIP 3 controls the fan mode (SMT-710 control fan or Heater control fan).

DIP 2 ON (Heat Pump Mode) Dip 3 controls the reversing valve logic (Energise Cool- O or Heat- B)

LEDS

Data 

There are two sets of LEDES on the SMT-710.

The Data LED will flash whenever data is sent/received, typically every 5 seconds.

The Data LED flashing rapidly, on solid or doesn't flash at all suggest poor communication.

 Heat
 Cool
 Fan

Heat, Cool, Fan & the two Zone LEDES will illuminate to indicate that output is active.

 
Z1 Z2

No LEDES will be on if there is no power to the SMT-710 UCC.

Installer Option Menu

The SMT-710 has an extensive Installer options menu. From within this menu you are able to change many settings to tune the SMT-710 to the needs of the user or the project.

To enter the Installer menu

- 1 Ensure Mode = OFF
- 2 Press and hold the centre of the display.
- 3 When the display shows 15, use the Up/Down buttons to enter 21
(or to the new PIN if you have changed it from the default 21)
- 4 Press the lower right button to enter the installer menu

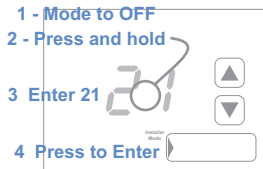

Once you are in the Installer Menu the Display right will be as shown. You can step forward and backwards through the menu with the Left / Right buttons and adjust the option numbers with the Up/Down button.

To exit the Installer menu, either wait 30 seconds or press and hold the lower right button for 5 seconds.

All settings will be stored into memory 30 seconds **AFTER** you exit the installer menu. Do Not power down within this 30 second window or your changes may be lost.

The menu shown on the following pages will give you the Installer option number and the options that can be applied to that function. The default options are highlighted.

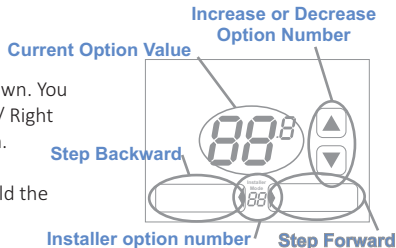

Installer Option List (a)

Option 0 Installer entry PIN

0-99 (Default 21)

Option 1 Buttons shown

- 0- Both Mode and Fan button shown (Default)
- 1- Show mode but hide fan
- 2- Show fan but hide mode
- 3- Both mode and fan buttons hidden.

Option 2 Permitted User Modes

- 0- Off / Auto
- 1- Off / Auto / Heat / Cool
- 2- Off / Heat / Cool (Default)
- 3- Off / Heat
- 4- Off /Cool
- 5- Off / Auto (display current heat or cool mode)

Option 3 Room / Set Display

- 0- Show room and set temp (Default)
- 1- Show set temp only

Option 4 Display Format

- 0- Deg C (Default)
- 1- Deg F

Option 5 C/F button shown on the LCD

- 0- Off (Default)
- 1- Show swap C/F button on LCD

Option 6 Heat Temp High Set Limit

5 to 50 C (Default 35)

Option 7 Cool Temp Low Set Limit

5 to 50 C (Default 15)

Option 8 Dead Band

0 to 5.0C (Default 0.5c)

Option 9 Heat Relay Span

0.5 to 10.0c (Default 1.0c)

Option 10 Cool Relay Span

0.5 to 10.0c (Default 1.0c)

Option 11 Fan Relay Span

0.5 to 10.0c (Default 1.0c)

Option 12 Fan Purge

- 0- Off (Default)
- 1- Purge 1 minute
- 2- Purge 3 minutes
- 3- Purge 5 minutes
- 4- Purge 10 minutes
- 5- Purge Heat mode 1 min
- 6- Purge Heat mode 3 min
- 7- Purge Heat mode 5 min
- 8- Purge Heat mode 10 min
- 9- Purge Cool mode 1 min
- 10- Purge Cool mode 3 min
- 11- Purge Cool mode 5 min
- 12- Purge Cool mode 10 min

Installer Option List (b)

Option 13 Assignable Relay Function

- 0- Close on fault (Default)
- 1- Y2 (in HP or HC mode)
- 2- W2 (In Heat cool mode)
- 3- Spill- Opens when all zones are closed
(when option 38 = 0)

Option 14 0-10V Heat Relay Span

0.5 to 10.0c (Default 1.0c)

Option 15 0-10V Heat Interval PI

10- 300 Seconds (60 Seconds default)

Option 16 0-10V Heat Direction

- 0- 0-10V (valve opens as more heat required) (Default)
- 1- 10-0V (valve closes as more heat required)

Option 17 0-10V Heat Minimum Voltage

0-10v 0.1 steps (Default 0v)

Option 18 0-10V Cool Relay Span

0.5 to 10.0c (Default 1.0c)

Option 19 0-10V Cool Interval PI

10- 300 Seconds (60 Seconds default)

Option 20 0-10V Cool Direction

- 0- 0-10V (valve opens as more heat required) (Default)
- 1- 10-0V (valve closes as more heat required)

Option 21 0-10V Cool Minimum Voltage

0-10v 0.1 steps (Default 0v)

Option 22 0-10Fan Span

0.5 to 10.0c

Option 23 0-10V Fan Interval PI

10- 300 Seconds (60 Seconds default)

Option 24 0-10V Fan Direction

- 0- 0-10V (valve opens as more heat required) (Default)
- 1- 10-0V (valve closes as more heat required)

Option 25 0-10V Fan Minimum Voltage

0-10v 0.1 steps (Default 0v)

Option 26 0-10V Fan Maximum Voltage

0-10v 0.1 steps (Default 10v)

Option 27 Auto Off Timer

- 0- Auto Off Timer disabled (Default)
- 1 to 10 hours.

Option 28 Un=Occupied Heat Set point

- 0- Off (Default 15)
- 5-35C

Option 29 Un=Occupied Cool Set point

- 0- Off (Default 27)
- 5-35C

Installer Option List (C)

Option 30 Un=Occupied Fan Speed / Mode (1 or 3 speed)

- 1- Low (Auto) (Default) 1- Auto 1 speed fan (Default)
- 2- Medium (Auto)
- 3- High(Auto)
- 4- Low (On) 4- On 1 speed fan
- 5- Medium (On)
- 6- High(On)

Option 31 Back light

- 0- On with button press (Default)
- 1- Always high
- 2- Low in standby & high when touched

Option 32 TT Terminal Functions

- 0- Remote sensor (replaces on board sensor) (Default)
- 1- Average remote sensor with onboard sensor
- 2- Force un-occupied
- 3- Fault

Option 33 Assignable Input Function

- 0- Remote sensor (replaces on board sensor)
- 1- Average remote sensor with onboard sensor
- 2- Force un-occupied
- 3- Fault
- 4- Force Off
- 5- Warm Start (Default)
(HP mode only - delays indoor fan till 25c or 30 seconds)

Option 34 Temperature Sensors Sensor speed of response

- 0- Very fast
- 1- Fast
- 2- Normal
- 3- Slow (Default)
- 4- Very Slow

Option 35 TT Temperature Calibration

- +/- 10c (Default 0.0c)

Option 36 Wall controller Temperature Calibration

- +/- 10c (Default 0.0c)

Option 37 Zone 2 Temperature Calibration

- +/- 10c (Default 0.0c)

Option 38 Zone Management (see Zone Logic - next page)

- 0- NO default zone. Both zones can be closed
- 1- Zone 1 is default.
(zone 1 will auto turn on to keep a zone open)
- 2- Zone 2 is default
(zone 2 will auto turn on to keep a zone open)
- 3- No default Zone- cannot turn off last zone (Default)

Installer Option List (d)

Option 39 Fault Input action

- 0- Only display Fault on LCD- no action required
- 1- Shut down HVAC- No display on LCD
- 2- Shut down HVAC and display on LCD (Default)
- 3- Shut down HVAC after 15 seconds- no display on LCD
- 4- Shut down HVAC after 15 seconds- display on LCD

Option 40 Modbus Mode

- 0- SP7 communication (Inc temperzone & BMS)(Default)
- 1-Intesis Module
- 2- SMT-UI

Option 41 Modbus Address (only if Option 34 = 3)

- 1- 255 (Default 7)

Option 42 Modbus Baud (only if Option 34 = 3)

- 0- 4800
- 1- 9600
- 2- 19200 (Default)

Option 43 Modbus Parity (only if Option 34 = 3)

- 0- None
- 1- Odd
- 2- Even (Default)

Option 44 Dec x 10 for Intesis or SMT-UI-DK Module

- 0- Disable
- 1- Enable

Option 45 Safety Heat set limit.

- Range 5 to 38 Default Off

Option 46 Safety Cool set limit

- Range 7 to 40 Default Off

Option 47 Fan limit on Zone number

- 0- Off
- 1- Limit to Low Fan when only 1 zone
- 2- Limit to Low & Med Fan when only 1 zone

R Factory reset

Set to value to 1 (one) and exit to initiate

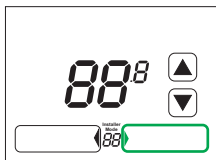

To exit the installer menu press and hold the lower right button for 5 seconds.

The installer menu will auto exit if no button presses have been detected within 30 seconds.

Do not power the SMT-710 down for 30 seconds to preserve changes

Typical 2 Stage Heat Pump- 3 Fan Speeds

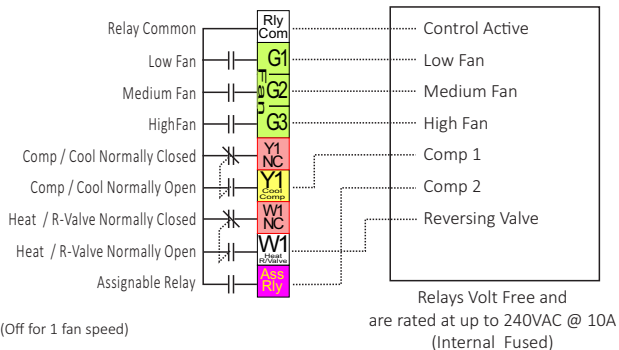

DIP 1 On (3 Fan Speeds)- (Off for 1 fan speed)

DIP 2 On (Heat Pump)

DIP 3 Off for RV in Cool (O)

DIP 3 On for RV in Heat (B)

DIP 4 to 8 Installer Choice

Set Installer Option 13 = 1

If connecting to a single fan speed system, don't wire to the G2 (med fan speed) G3 (high fan speed) outputs and turn DIP 1 off. (Power cycle the UCC after changing any DIP switches)

Typical 2 Heat 1 Cool - 1 Fan Speed

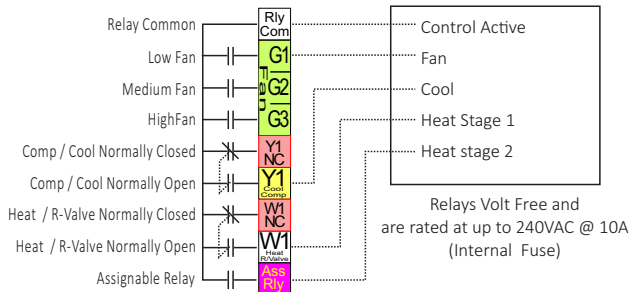

DIP 1 Off - 1 Fan Speed. (On if 3 Fan Speeds)

DIP 2 OFF - Heat Cool

DIP 3 Off if Equipment Control Heater Fan

DIP 3 On if SMT-710 controls Heater Fan

DIP 4 to 8 Installer Choice

Set Installer Option 13 = 2 (W2 In HC Mode)

If connecting to a three fan speed system, wire to the G2 (med fan speed) G3 (high fan speed) outputs and turn DIP 1 On. (Power cycle the UCC after changing any DIP switches)

Typical Wiring HVAC Systems

Typical 1 Stage Heat Pump with Water Flow Interlock *Using an Isolating Relay*

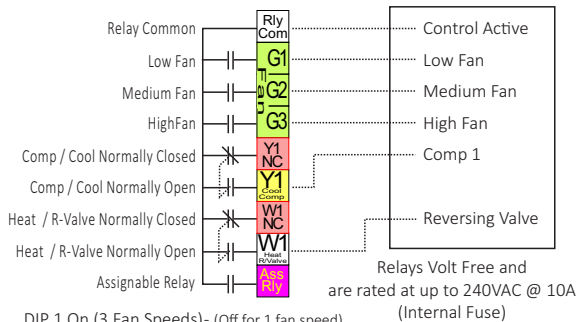

DIP 1 On (3 Fan Speeds)- (Off for 1 fan speed)

DIP 2 On (Heat Pump)

DIP 3 Off for RV in Cool (O)

DIP 3 On for RV in Heat (B)

DIP 4 to 8 Installer Choice

To water flow switch

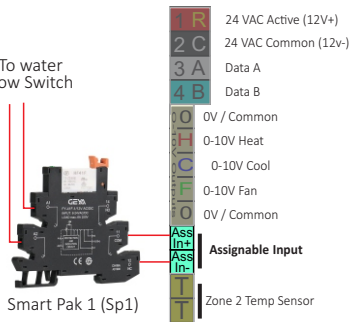

Flow interlocks are mostly failsafe therefore use the normally closed and common relay terminals. If the logic is different in your application use the common and normally open terminals

If connecting to a single fan speed system, don't wire to the G2 (med fan speed) G3 (high fan speed) outputs and turn DIP 1 off. (Power cycle the UCC after changing any DIP switches)

Typical 1 Stage Heat Pump with 0-10V Capacity Control

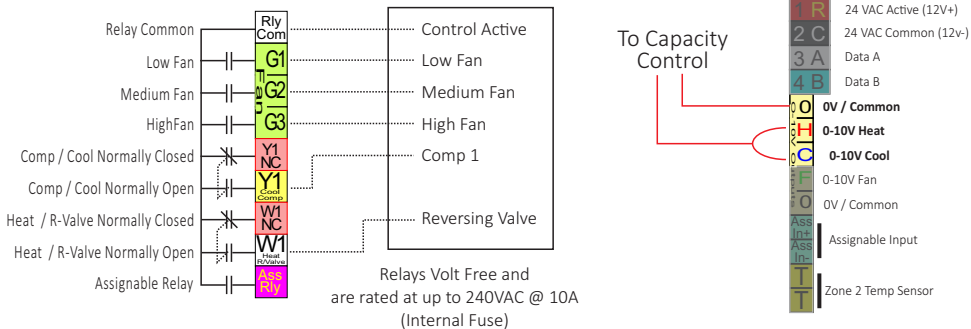

DIP 1 On (3 Fan Speeds)- (Off for 1 fan speed)

DIP 2 On (Heat Pump)

DIP 3 Off for RV in Cool (O)

DIP 3 On for RV in Heat (B)

DIP 4 to 8 Installer Choice

If connecting to a single fan speed system, don't wire to the G2 (med fan speed) G3 (high fan speed) outputs and turn DIP 1 off. (Power cycle the UCC after changing any DIP switches)

Zone Dampers

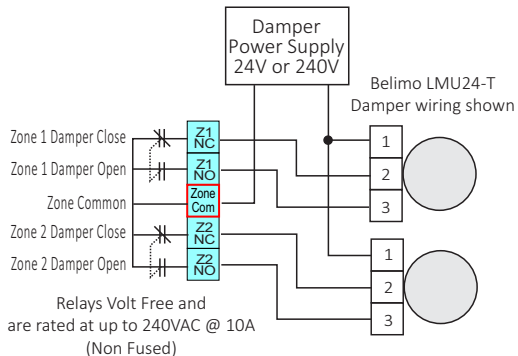

The SMT-710 can also control 2 zone dampers. These dampers will direct the flow of conditioned air (or open/close a water valve) to permit each zone temperature to be controlled.

To enable this functions SW 8 on the Unit Control Card must be ON.

The zone dampers are simple open closed type and can be any voltage up to 240V.

You can additionally add a zone 2 temperature sensor that will automatically control Zone 2 damper based on room and set temperature.

Inputs

Zone 2 Sensor



The Zone 2 temperature sensor can be optionally fitted to the Unit Control Card's "TT" terminals to permit the SMT-710 to actively control Zone 2 Temperature.

The SMT-710 will automatically detect a sensor that is wired to this input and function accordingly.

Assignable Input



The Assignable input in the SMT-710 can be configured to measure a volt free switch status or to measure temperature from a 10K NTC temperature sensor.

This input's functions are selectable in the installer options menu. (Option 33).

**DO NOT APPLY
POWER TO THIS INPUT**

Remote Zone 1 Sensor

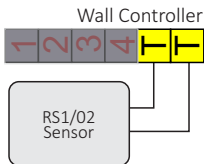

If the SMT-710 Wall Controller is located in an area not typical of the space temperature you wish to control, you are able to install a standard 2 wire Smart Temp temperature sensor (Such as the RS1/02), wired to the "TT" terminals in the wall controller, moving the sensing location to the new sensor location.

The SMT-710 will auto detect this sensor when installed.

Specifications

Power Requirement	12 AC or DC to 28V AC / DC
Recommended Transformer	SZ-PS 24V 7VA
Control Range	5yes providec to 35C
Relay Rating	10A at 240V max (15A Total fused)
Temperature Sensor type	10K NTC Type II (RS-01/2 or RS1D)
Maximum Z2 sensor run	10M Un-screened (30M Max)
Backlight	White LED
WiFi	2.4 GHz Wi-Fi IEEE 802.11b/g/n
Wall Controller Size	110 x 105 x 38 mm
Unit Control Card Size	145 x 112 x 66
Storage Conditions (max)	-5c to 80c @ 90% RH (Non Condensing)
Operating Conditions (max)	0 to 45c @ 90% RH (Non Condensing)
Warranty	2 Years- RTB